



Agni Instruments Engineers (INDIA) Pvt. Ltd.

SIMPLEX TYPE TALKBACK SLAVE STATION

Product Overview

Agni Slave Talk-back Unit Can Communicate With Main Talk-back Master Panel. At Slave Unit After Pressing Ptt Switch Signal Comes On Main Master Panel Control Room Can Receive Call By Pressing Ptt Switch At Master Panel, and By This Indication Also Know Which Floor/zone Number Or Location Slave Unit Is Calling To Master Station. This Is A Simple Mod Of Communication.



DEVICE COMPLIANCE
Indian Standard -2189
SELECTION, INSTALLATION AND MAINTENANCE
 OF AUTOMATIC FIRE DETECTION AND ALARM
 SYSTEM CODE OF PRACTICE
 2175: 1988
ERTL TESTED
 ★★★★★

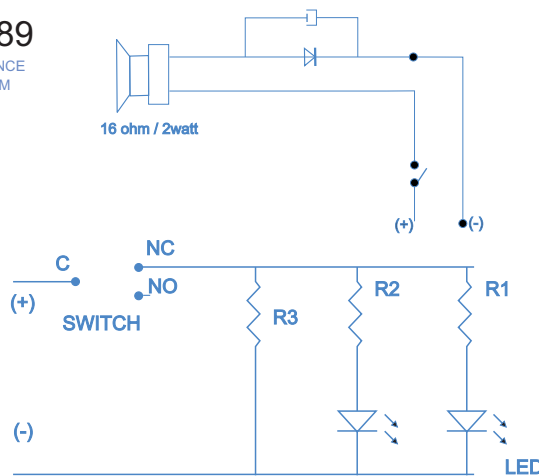

Voice Communication

TECHNICAL DATA SHEET

PARAMETER	DATA	11. Colour of LED	Red / Green (Talk-Back)
1. Make	Agni Instruments Engineers (I) Pvt. Ltd.	12. Size of LED	5mm
2. Model	AGNI-505	13. Type of LED	Diffuse Type
3. Construction Material	16/18 SWG MS CRCA Sheet, Red Powder Coated	14. LED Status	Normal OFF, Fire ON
4. Colour	Signal Red	15. Sign Writing	In Case of fire Break Glass
5. Dimensions	H240xW135xD65mm	16. Speaker	16 ohm 2WATT.
6. Cable Entry	Top	17. Operating Voltage	24V DC
7. Mounting Holes	2 Nos (4mm)	18. Alarm Contact	C, NC
8. Knock Out	19mm	19. Alarm Resistance	560ohm/1 Watts
9. Fragile Element	2mm Thick Glass	20. Stand By Current	NIL
10. Break Glass Area	30sq. cm	20. Switch	Press to ON, Press to OFF